

### Front Suspension

Ride Height: \_\_\_\_\_  
 Camber: \_\_\_\_\_  
 Toe: \_\_\_\_\_  
 Anti-Roll Bar: \_\_\_\_\_  
 Arm Type: \_\_\_\_\_  
 Tower Type: \_\_\_\_\_  
 Wheel Hex: \_\_\_\_\_  
 Steering Block KPI: \_\_\_\_\_  
 Caster Block Insert: 0  +2.5  +5   
 Bulkhead Type: \_\_\_\_\_  
 Kick-Up Angle: -2.5  0  +2.5   
 Steering Stop Spacing: \_\_\_\_\_  
 Caster Block Spacing: Fwd  Back

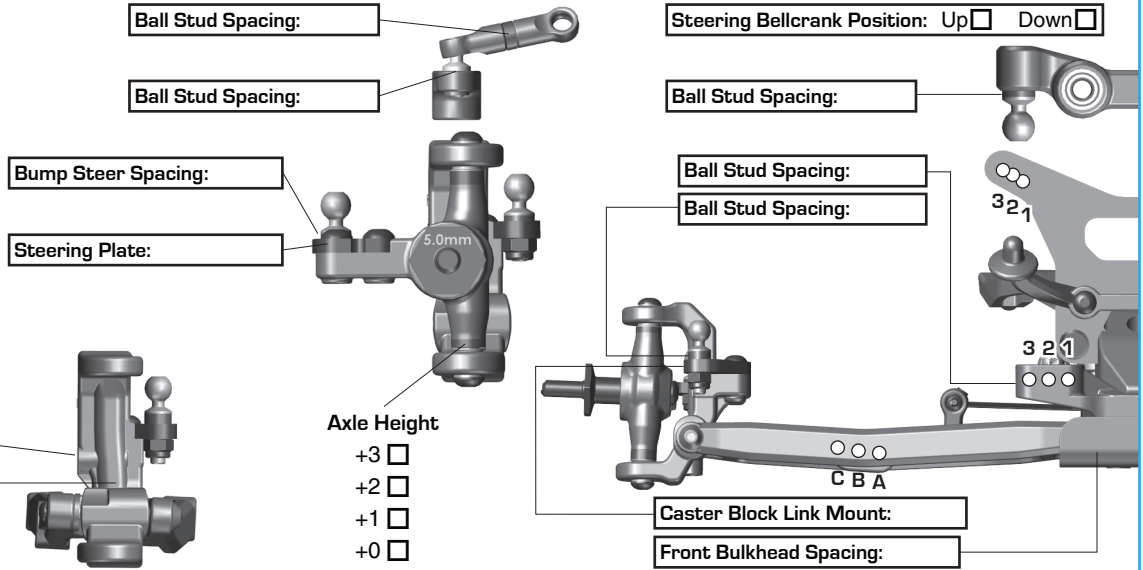

### Rear Suspension

Ride Height: \_\_\_\_\_  
 Camber: \_\_\_\_\_  
 Anti-Roll Bar: \_\_\_\_\_  
 Arm Type: \_\_\_\_\_  
 Tower Type: \_\_\_\_\_  
 Arm Spacing: Fwd  Mid  Back   
 Wheel Hex: \_\_\_\_\_  
 Hub Type: Std  HRC   
 Hub Spacing: Fwd  Mid  Back   
 Drive Shaft: CVA's  Universals

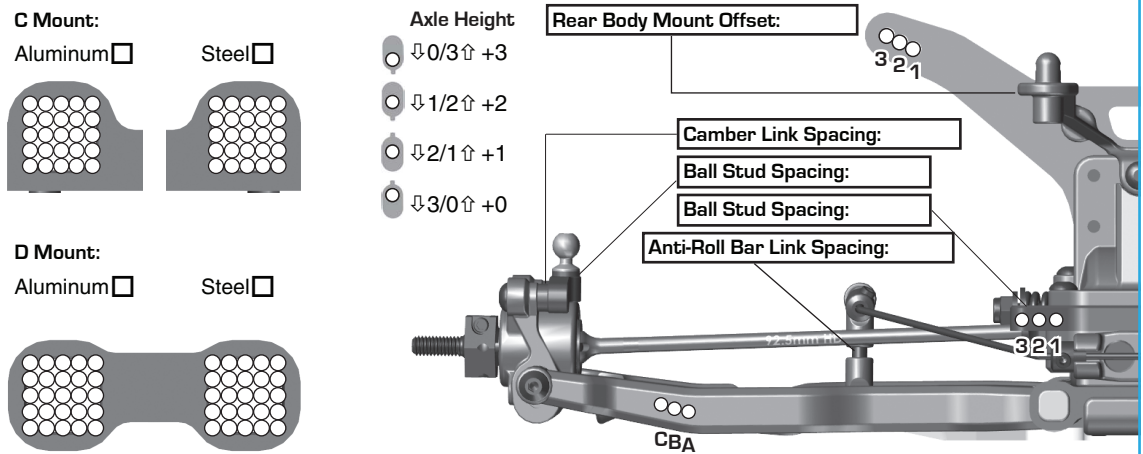

### Electronics

Radio: \_\_\_\_\_ Servo: \_\_\_\_\_  
 EPA: Throttle: \_\_\_\_\_ % Brake: \_\_\_\_\_ %  
 ESC: \_\_\_\_\_  
 ESC Settings: \_\_\_\_\_  
 Motor / Wind: \_\_\_\_\_ Timing: \_\_\_\_\_  
 Pinion: \_\_\_\_\_ Spur: \_\_\_\_\_  
 Battery Mount: Std  Offset   
 Back 1  2  3  4  5  Forward  
 Battery: \_\_\_\_\_ Weight: \_\_\_\_\_

### Drivetrain

Differential Ball  Steel   
 Height: \_\_\_\_\_  
 Setting: \_\_\_\_\_

### Slipper Clutch

Type: \_\_\_\_\_  
 # of Pads: \_\_\_\_\_  
 Setting: \_\_\_\_\_

### Shocks

	Front		Rear	
Piston:				
Thickness:				
Fluid:				
Spring:				
Limiters:	In:	Out:	In:	Out:
Stroke:				
Eyelet:				
Cup Offset:	0 <input type="checkbox"/> +5 <input type="checkbox"/> +9 <input type="checkbox"/>		0 <input type="checkbox"/> +5 <input type="checkbox"/> +9 <input type="checkbox"/>	
Kashima Bodies <input type="checkbox"/> Chrome Shafts <input type="checkbox"/> Machined Spacers <input type="checkbox"/>				



### Track Information

Size: \_\_\_\_\_  
 Composition: \_\_\_\_\_  
 Traction: \_\_\_\_\_  
 Moisture: \_\_\_\_\_  
 Surface: Bumpy  Smooth    
 Temperature: \_\_\_\_\_

### Tires

Front Tires: \_\_\_\_\_  
 Front Compound: \_\_\_\_\_  
 Front Insert: \_\_\_\_\_  
 Rear Tires: \_\_\_\_\_  
 Rear Compound: \_\_\_\_\_  
 Rear Insert: \_\_\_\_\_  
 Wheel (F/R): \_\_\_\_\_

### Body & Weight

Body: \_\_\_\_\_  
 Rear Wing: \_\_\_\_\_  
 Chassis Length: \_\_\_\_\_  
 Servo Weights: \_\_\_\_\_  
 Electronic Weights: \_\_\_\_\_  
 Total Vehicle Weight: \_\_\_\_\_

### Comments

\_\_\_\_\_